

Werk

Label: Article

Jahr: 1985

PURL: https://resolver.sub.uni-goettingen.de/purl?316342866_0026|log36

Kontakt/Contact

[Digizeitschriften e.V.](#)
SUB Göttingen
Platz der Göttinger Sieben 1
37073 Göttingen

✉ info@digizeitschriften.de

CHANGES OF THE OUTCOME OF COMBINATORIAL GAMES
WITH DIFFERING NUMBER OF PROHIBITED REPETITIONS
Igor KRÍŽ

Abstract: For any finite sequence i_1, i_2, \dots, i_n with $i_j \in \{1, 2\}$ there is a finite game won for the i_k -th player in case of at most k repetitions of a state allowed.

Key words: Combinatorial games, valuation according to prohibited repetitions.

Classification: 90 D 05

In combinatorial games (of two persons with full information), a player is usually declared to lose an individual play if he cannot move while being on move. The other player is then declared a winner. Or, one can use the opposite valuation ("miserère"), which does not change the character of the games substantially. In [3], another valuation has been studied, namely a player has lost also when forced to move into a position he had been already in. In the more general case, a position was allowed to enter at most k times and the $k+1$ -st entry was considered as loss (this valuation rule is called the $(k+1)$ -st repetition ban, briefly kRB). This has been shown to increase drastically the complexity of playing the game.

It was observed that the outcome of a game under kRB and $k'RB$ with distinct k, k' can differ and a question arose as to how arbitrary these changes might be. In this note we are solving

this problem by proving that they can be very arbitrary indeed: for any finite sequence i_1, \dots, i_n ($i_k \in \{1, 2\}$) there is a finite game won for the i_k -th player under kRB.

1. Preliminaries

1.1. A combinatorial game of two players (in the sequel simply a game) is a quadruple (X, A, B, x_0) where X is a set (of positions), $A \subset X \times X$ resp. $B \subset X \times X$ are rules of the first resp. second player, x_0 is the initial position. In the sequel we shall assume X finite.

A play is a sequence $x_0 x_1 x_2 \dots$ of positions, arising from alternating moves of both players (the first player begins with $x_0 \rightarrow x_1$). The players have to obey the rules, i.e. it has to be $x_{2i} x_{2i+1} \in A$, $x_{2i-1} x_{2i} \in B$. In the standard valuation, the play ends when one of the players cannot move. This player is said to lose and the other one to win. An infinite play is declared to be a draw.

It is well known that in each game either one of the players has a winning strategy, or both can achieve a draw. (Throughout this note, the word "strategy" is considered in the wide sense, i.e. stands for a procedure specifying, according to the play so far developed, a set of positions from which the player in question can choose next [4, 2].)

1.2. In this paper, we will consider a modified valuation of the outcome of games, namely the $(k+1)$ -st repetition ban (kRB), (cf. [3]) declaring a game as lost for a player, who moves into a position he has been in k times already. Evidently, this law

prevents draws in finite games. It is easy to show that a game already won for a player doesn't change the value under a kRB (see [3]). In section 2 we show that the value of draw games can substantially vary with the k; indeed, given a finite sequence $S=(i_1, \dots, i_n)$, $i_j=1$ or 2 , there is always a game G such that under kRB it is won for the i_k -th player.

1.3. We will accept the notation of Pultr-Morris [3]:

The expression

$$\xi \xrightarrow{X} \eta \quad (+)$$

means the move of the player X from ξ to a position (or, possibly, a group of positions), indicated by η ;

$$\xi \xrightarrow{Xopt} \eta \quad (++)$$

means an optional move (this is used only when X is the winner) and REP indicates a losing position.

Since we consider general kRB-s, with, possibly, large k , it is not always possible to run through plays to the very end. Thus, we need also a symbol for certain kind of cycles (similarly, as in proofs of program correctness). Of course, we could make with the symbols $(+)$, $(++)$, allowing loops in the diagrams of plays. This, however, would lead to diagrams of nearly the same degree of obscurity, as the original description of a game.

We will accept a compromise, allowing only special, "typized" kinds of cycles of the following form:

The symbol

$$\begin{array}{c} \longrightarrow \{ \eta \longrightarrow \dots \longrightarrow \xi \}_Q \longrightarrow \\ \text{will stand for} \\ \longrightarrow \underbrace{\eta \longrightarrow \dots \longrightarrow \xi}_Q \longrightarrow \end{array}$$

where Q is the usual qualifier of a move (of the form $X, Xopt$). Those cycles will be called loops and will be labeled by marks

(*), (+), etc. in the text.

An additional symbol $\text{REP}(\xi)$ will be used to indicate the number of times the position ξ was already entered. Since in all the games in the sequel both players have distinct positions to move to, this notation cannot cause a misunderstanding.

For a useful example see 2.3.

2. The construction

2.1. Theorem: For any set $M \subseteq \mathbb{N}$ that is finite or has a finite complement a finite game $G(M)$ exists with the following property:

(P) $G(M)$ is won for the first player under $k\text{RB}$ iff $k \in M$ (and won for the second player otherwise).

The Theorem will be proved in 2.5. below.

In the sequel, all games will be played under $k\text{RB}$ with varying k . Thus, we reserve the letter k to indicate the variable specifying the $k\text{RB}$ -s.

2.2. The main idea of the proof is to construct games $F(n)$ won for the first player if $k \leq n$ and won for the second player otherwise. From those games a general $G(A)$ is constructed easily (see 2.5.). The game $F(n)$ is glued together from n copies of certain segment TRAP with the property that the first player is allowed to enter it at most one time. In case of $k \leq n$ the first player wins forcing the second player to reenter the loop k times. In case of $k > n$ he loses, being forced to reenter one of the TRAPs twice.

2.3. The game TRAP = $(\bar{X}, \bar{A}, \bar{B}, r)$ with
 $\bar{X} = \{r, a, bo, bl, c, d, eo, el\}$
 is depicted in fig.1

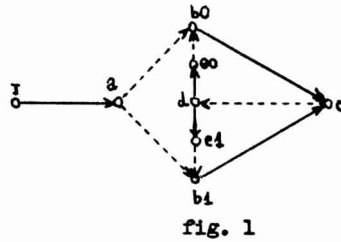

fig. 1

(\bar{A} is indicated by the full arrows, \bar{B} by the dotted ones.)

Proposition 1: The game TRAP is won for the first player.

In the sequel, we shall write simply I instead of the first player and II instead of the second player.

Proof: I proceeds as follows:

$$a \xrightarrow{I} \{bo \xrightarrow{I} c \xrightarrow{II} d \xrightarrow{Iopt} eo\}_{II} \quad (1)$$

$$a \xrightarrow{I} \{bl \xrightarrow{I} c \xrightarrow{II} d \xrightarrow{Iopt} el\}_{II} \quad (2)$$

It is obvious that I cannot lose, since in both (1) and (2) it holds

$$REP(bl) \geq REP(c), REP(d), REP(e1)$$

at any time. \square

2.4. Now we define the game $F(n) = (X_n, A_n, B_n, \mathcal{G})$ as follows.

For simplicity reasons, elements of cartesian products in complex expressions are denoted by juxtaposition (ab instead of (a,b)).

$$\begin{aligned}
X_n &= \{\xi, \xi', x\} \cup \{1, \dots, n\} \times (\bar{X} \setminus \{x\}) \\
A_n &= \{(\xi, \xi')\} \cup \{(x, 1a) \mid 1 = 1, \dots, n\} \cup \\
&\quad \cup \{(1\xi, 1\eta) \mid (\xi, \eta) \in \bar{A} \setminus \{(x, a)\}, 1 = 1, \dots, n\} \\
B_n &= \{(\xi', x)\} \cup \\
&\quad \cup \{(1\xi, 1\eta) \mid (\xi, \eta) \in \bar{B}, 1 = 1, \dots, n\} \cup \\
&\quad \cup \{(1c, x) \mid 1 = 1, \dots, n\}
\end{aligned}$$

(see fig.2)

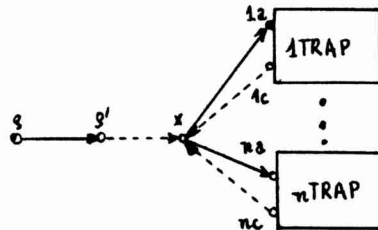

fig.2

Proposition 2: The game $F(n)$ is won for the first player if $k \leq n$ and won for the second player otherwise.

Proof: Assume $k \leq n$. The play will start

$$\xi \xrightarrow{I} \xi' \xrightarrow{II} x \xrightarrow{I_{opt}} 1a$$

Then II either stays in 1TRAP and, in consequence, loses by Proposition 1, or plays

$$1c \xrightarrow{II} x$$

sooner or later. Then I continues

$$x \xrightarrow{I_{opt}} 2a.$$

The previous situation is repeated in 2TRAP, forcing II to play

$$2c \xrightarrow{II} x$$

sooner or later. A general answer of I to

$$1c \xrightarrow{II} x$$

will be

$$x \xrightarrow{I_{opt}} (i+1)a.$$

We see easily that the second player loses by

$$kc \xrightarrow{\text{II}} x$$

having repeated the position x $(k+1)$ -st time.

Assume now $k > n$. The play will go as follows:

$$\zeta \xrightarrow{\text{I}} \zeta' \xrightarrow{\text{II}} x \xrightarrow{\text{I}} ia \xrightarrow{\text{II}_{\text{opt}}} ibo \xrightarrow{\text{I}} ic \xrightarrow{\text{II}} x$$

Then I has to choose some of the moves

$$x \xrightarrow{\text{I}} ja$$

and II continues by

$$ja \xrightarrow{\text{II}_{\text{opt}}} jbo \xrightarrow{\text{I}} jc \xrightarrow{\text{II}} x.$$

The second player will follow this strategy, until I enters one of the positions ja second time. (Note that this definitely happens before II could lose by $k+1$ repetitions of x .)

At this moment we have

$$\text{REP}(ja) = 2$$

$$\text{REP}(jc) = \text{REP}(jbo) = 1$$

and

$$\text{REP}(t) = 0$$

for other positions t of JTRAP . Now II wins as follows:

$$ja \xrightarrow{\text{II}_{\text{opt}}} jbl \xrightarrow{\text{I}} jc \xrightarrow{\text{II}_{\text{opt}}} \left\{ \begin{array}{l} jd \xrightarrow{\text{I}} jco \xrightarrow{\text{II}} jbo \xrightarrow{\text{I}} jc \\ jd \xrightarrow{\text{I}} jcl \xrightarrow{\text{II}} jbl \xrightarrow{\text{I}} jc \end{array} \right\}_{\text{II}_{\text{opt}}} (*)$$

The play necessarily ends in the loop $(*)$. But we see easily that in this loop

$$\text{REP}(jc) \geq \text{REP}(jd), \text{REP}(jbo), \text{REP}(jbl)$$

holds any time, preventing the loss of II. \square

2.5. Proof of Theorem 2.1.: Consider a set $M \subseteq \mathbb{N}$ that is finite or has a finite complement. We will assume $1 \in M$:

In the opposite case we construct the game $G(\mathbb{N} \setminus M)$ and we obtain $G(M)$ by flipping the rules and adding one position before the origin so that the first player becomes second and vice versa.

Now it is obvious that there exists a finite increasing sequence $0 = a_0, a_1, \dots, a_n$ such that the segments

$$\begin{aligned} I_1 &= \{1, \dots, a_1\} \\ I_2 &= \{a_1+1, \dots, a_2\} \\ &\vdots \\ I_n &= \{a_{n-1}+1, \dots, a_n\} \\ I_{n+1} &= \{a_n+1, a_n+2, \dots\} \end{aligned}$$

belong to the sets $M, \mathbb{N} \setminus M$ alternately ($I_1 \subseteq M$).

Construct the game $G(M) = (X, A, B, \sigma_1)$ as follows ($\lfloor \cdot \rfloor$ resp. $\lceil \cdot \rceil$ means lower resp. upper integral part; the symbols A_i, B_i are taken from 2.4.):

$$\begin{aligned} X &= \{\alpha_i \mid i = 1, \dots, n\} \cup \{1\xi \mid i = 1, \dots, n, \xi \in X_i \setminus \{\xi\}\} \\ A &= \{(\sigma_{2i-1}, (2i-1)\xi') \mid i = 1, \dots, \lceil n/2 \rceil\} \cup \\ &\cup \{(\sigma_{2i-1}, \sigma_{2i}) \mid i = 1, \dots, \lfloor n/2 \rfloor\} \cup \\ &\cup \{((2i-1)\xi, (2i-1)\eta) \mid (\xi, \eta) \in A_{2i-1} \setminus \{(\xi, \xi')\}, \\ &\quad i = 1, \dots, \lceil n/2 \rceil\} \cup \\ &\cup \{((2i)\xi, (2i)\eta) \mid (\xi, \eta) \in B_{2i}, i = 1, \dots, \lfloor n/2 \rfloor\} \\ B &= \{(\sigma_{2i}, (2i)\xi') \mid i = 1, \dots, \lfloor n/2 \rfloor\} \cup \\ &\cup \{(\sigma_{2i}, \sigma_{2i+1}) \mid i = 1, \dots, \lceil n/2 \rceil - 1\} \cup \\ &\cup \{((2i-1)\xi, (2i-1)\eta) \mid (\xi, \eta) \in B_{2i-1}, \\ &\quad i = 1, \dots, \lceil n/2 \rceil\} \cup \\ &\cup \{((2i)\xi, (2i)\eta) \mid (\xi, \eta) \in A_{2i} \setminus \{(\xi, \xi')\}, \\ &\quad i = 1, \dots, \lfloor n/2 \rfloor\} \end{aligned}$$

(see fig.3)

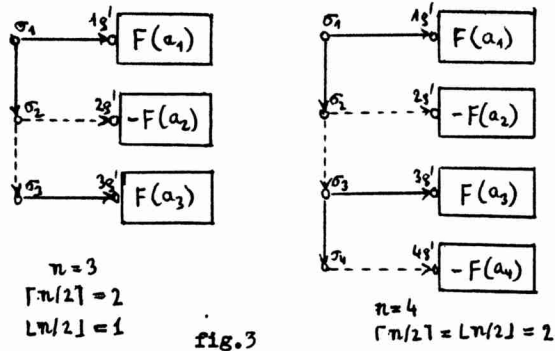

The symbol " $-F(a_1)$ " stands for the game $F(a_1)$ with the rules flipped: the first player enters $F(a_{21})$ as second and vice versa.

Now it is easy to show that $G(M)$ has the required property (P): Let $k \in (a_{i-1}, a_i)$. Then all the games $\pm F(a_j), j < i$ are lost for the player, who would play

$$\sigma_j \longrightarrow j s$$

Thus, the play comes to σ_i and the player on move (first in case of i odd and second in case of i even) wins by

$$\sigma_i \longrightarrow i s'$$

By a similar reason, the player who is on move in σ_n loses in case of $k > a_n$ (first in case of n odd and second in case of n even). Thus, the first player wins iff $a_{i-1} < k \leq a_i$ with an odd i , or $a_n < k$ with n even, in other words, if and only if $k \in A$. \square

2.6. Remark: Note that the construction of 2.5. works for infinite M as well, but the game $G(M)$ is then infinite. The real open problems concern, however, finite games. Obviously not all infinite sequences can be produced (since they are uncountably many and there are only countably many finite games). Are, for

instance, all recursive sequences produced? Or, are there only such that are eventually periodic after some finite pre-period? We cannot even decide whether they are not eventually constant.

Acknowledgement: I would like to thank A.Pultr for useful discussions of the manuscript.

References:

- [1] - Berge, C.: Sur une Théorie Ensembliste du Jeux Alternatifs. J.Math.Pures Appl. 32,1953,129-184.
- [2] - Kalmár, L.: Zur Theorie der Abstrakten Spiele. Acta Sci. Math.Univ.Szeged.4,1928,65-85.
- [3] - Pultr, A., Morris, F.L.: Prohibiting Repetitions Makes Playing Games Sustainably Harder. Int.J.Game Theory, Vol.13, Issue 1, page 27-40.

(Oblatum 3.10. 1984)